

Mechanical Data

- Surface Mount Package
- Case Material: Molded Plastic, UL Flammability Rating 94V-0
- Terminals: Finish - Matte Tin Plated Leads, Solderable per MIL-STD-202, Method 208 (e3)
- Weight: 0.0246 grams (Approximate)
- Max Soldering Temperature +260°C for 30 secs as per JEDEC J-STD-020

Package View

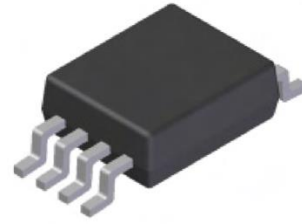

Package Outline Dimensions

MSOP-8

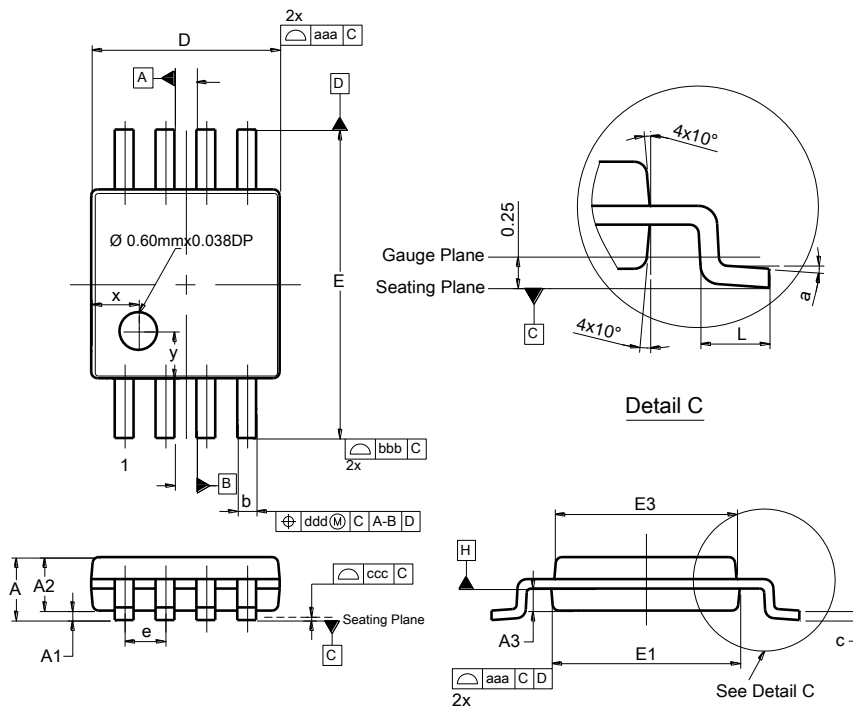

MSOP-8			
Dim	Min	Max	Typ
A	--	1.10	--
A1	0.05	0.15	0.10
A2	0.75	0.95	0.86
A3	0.29	0.49	0.39
b	0.22	0.38	0.30
c	0.08	0.23	0.15
D	2.90	3.10	3.00
E	4.70	5.10	4.90
E1	2.90	3.10	3.00
E3	2.85	3.05	2.95
e	--	--	0.65
L	0.40	0.80	0.60
a	0°	8°	4°
x	--	--	0.750
y	--	--	0.750
aaa	0.20		
bbb	0.25		
ccc	0.10		
ddd	0.13		
All Dimensions in mm			

Suggested Pad Layout

MSOP-8

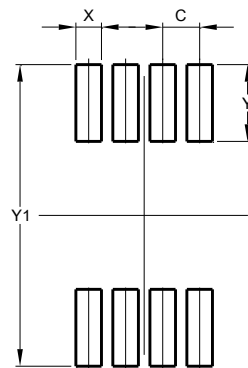

Dimensions	Value (in mm)
C	0.650
X	0.450
Y	1.350
Y1	5.300

Note: The suggested land pattern dimensions have been provided for reference only, as actual pad layouts may vary depending on application. These dimensions may be modified based on user equipment capability or fabrication criteria. A more robust pattern may be desired for wave soldering and is calculated by adding 0.2 mm to the 'Z' dimension. For further information, please reference document IPC-7351A, Naming Convention for Standard SMT Land Patterns, and for International grid details, please see document IEC, Publication 97.

Note: For high voltage applications, the appropriate industry sector guidelines should be considered with regards to creepage and clearance distances between device Terminals and PCB tracking.

Minimum Packing Quantity

	Quantity	Tape Width	Part Number Suffix
Bulk-Loose	100	n/a	n/a
7" Reel	1,000	12mm	TA
13" Reel	2,500	12mm	-13
13" Reel	4,000	12mm	TC

Note: Package quantities given are for minimum packaging quantity only, not minimum order quantity. For minimum order quantity, please contact Sales Department.

Note: No mixed date codes or partial quantity (less than minimum packaging quantity) per packaging is allowed.

Note: In no case shall there be two or more consecutive components missing from any reel for any reason.

Device Tape Orientation

Tape Width	Part Number Suffix	Tape Orientation
12mm	-13 TA TC	<p style="text-align: center;">Direction of feed </p>

Note: For part marking, refer to product datasheet.

Note: Tape and package drawings are not to scale and are shown for device tape orientation only.

Embossed Carrier Tape Specifications

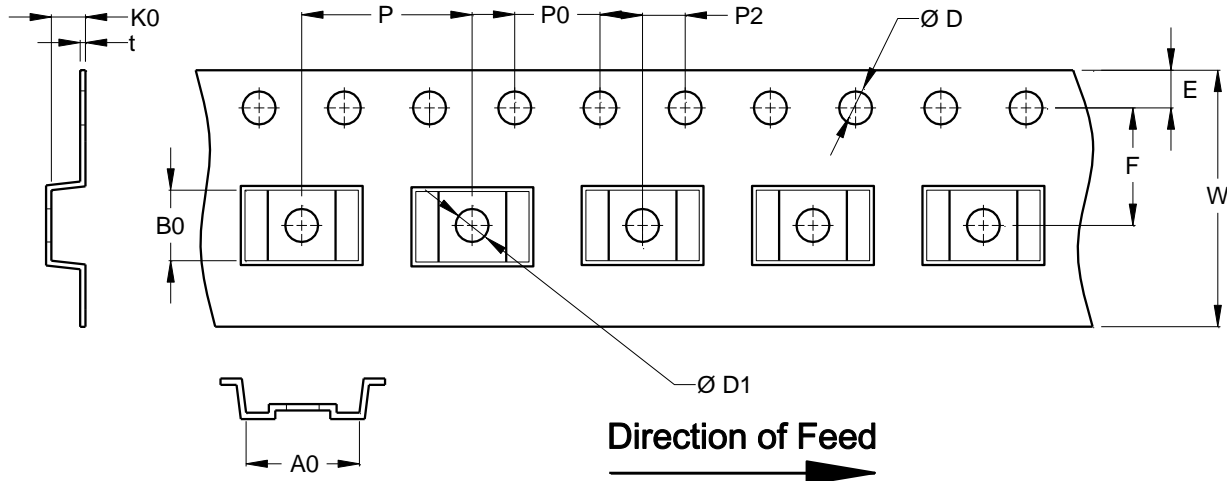

Tape Width (W)	Dimension	Value (mm)	Dimension	Value (mm)	Dimension	Value (mm)
12mm	A0	5.32 ±0.10	D1	1.55 ±0.05	P0	4.00 ±0.10
	B0	3.30 ±0.10	E	1.75 ±0.10	P2	2.00 ±0.10
	K0	1.42 ±0.10	F	5.50 ±0.05	t	0.30 ±0.05
	D	1.55 ±0.05	P	8.0 ±0.10	W	12.00 +0.2/-0.1
	A0 B0 K0	Determined by component size. The clearance between the component and the cavity must comply to the rotational and lateral movement requirement provided in figures in the "Maximum Component Movement in Tape Pocket" section.				

Embossed Carrier Tape Specifications (Continued)

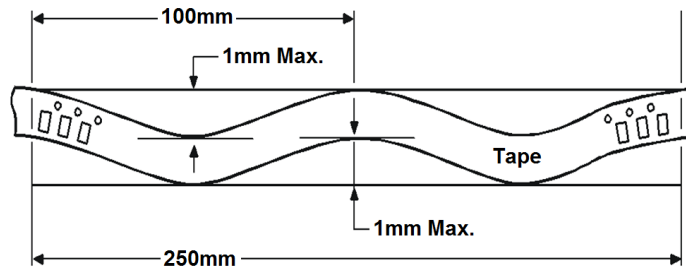
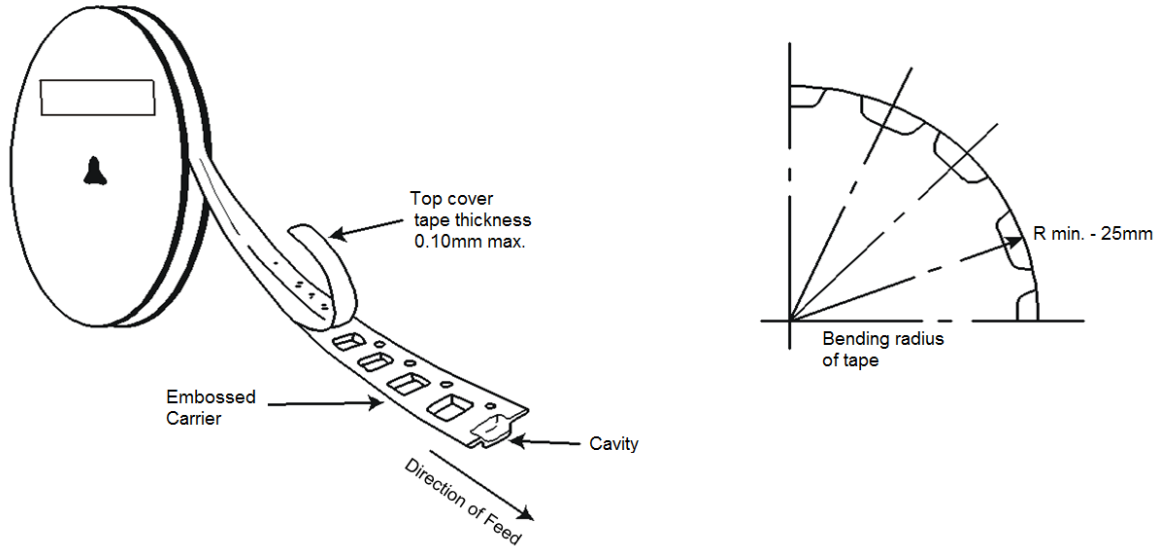

Camber (Top View)
Allowable camber to be 1mm/100mm tape, non-cumulative

Maximum Component Movement in Tape Pocket

Component Lateral Movement

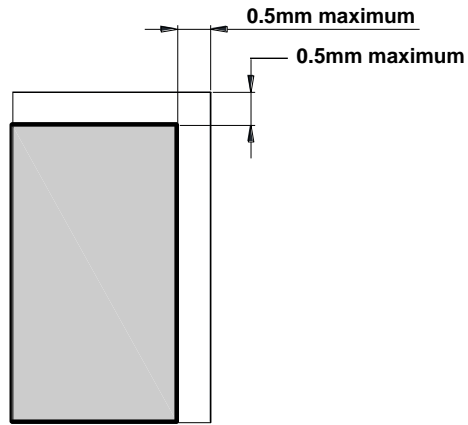

Maximum Component Rotation

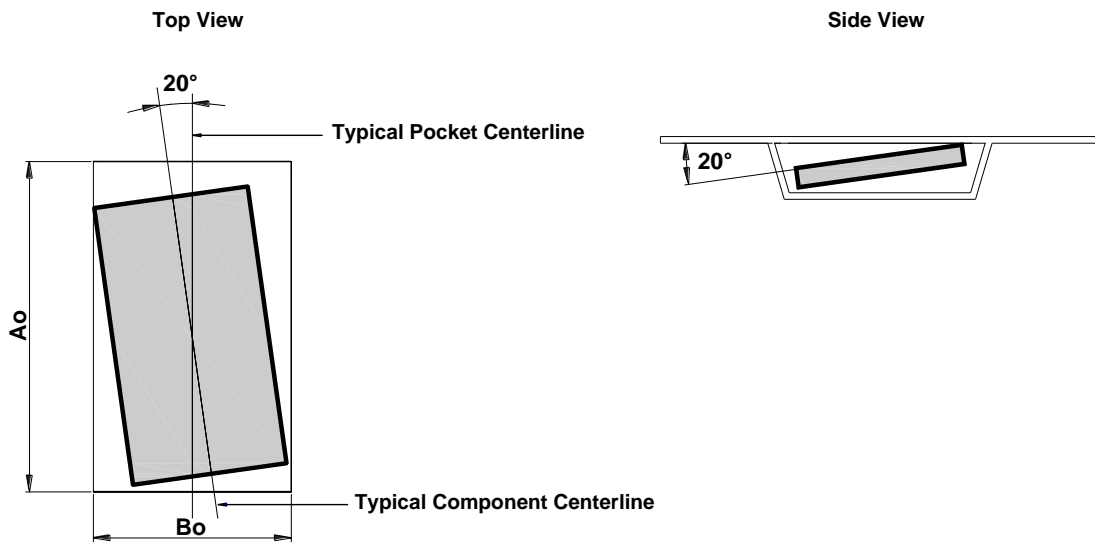

Surface Mount Reel Specifications

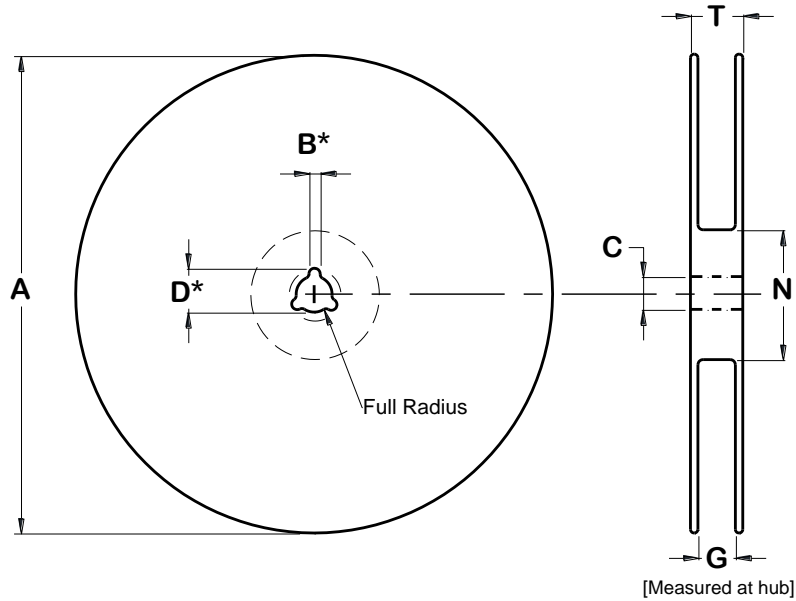

Tape Width	Reel Size	A (mm)	B* (mm)	C (mm)	D* (mm)	N (mm)	G (mm)	T (mm)
12mm	13"	330 ±2	2.0 +0.5 -0	13 ±1	20.5 ±0.2	50 (min)	14.4 (max)	18.4 (max)

Tape Leader and Trailer Specifications

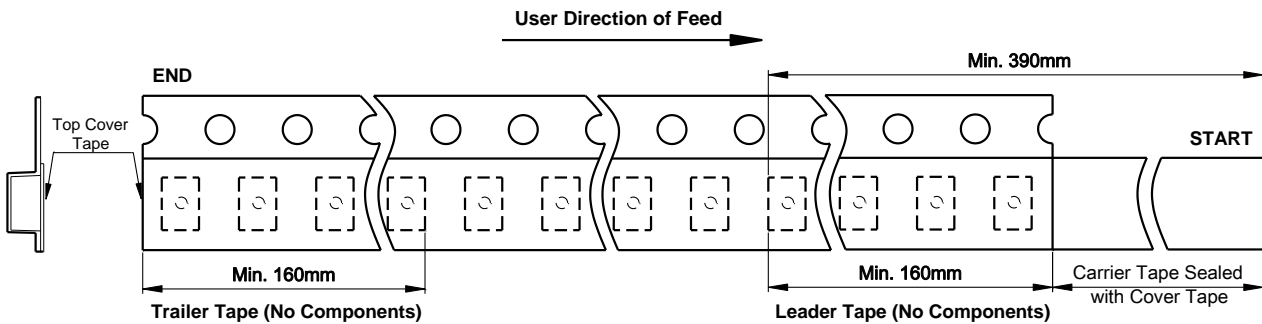

Note: There shall be a leader of at least 230mm which may consist of carrier tape and/or cover tape or a start tape followed by at least 160mm of empty carrier tape sealed with cover tape.

Note: There shall be a trailer of at least 160mm of empty carrier tape sealed with cover tape. The entire carrier tape must release from the reel hub as the last portion of the tape unwinds from the reel without damage to the carrier tape and the remaining components in the cavities.

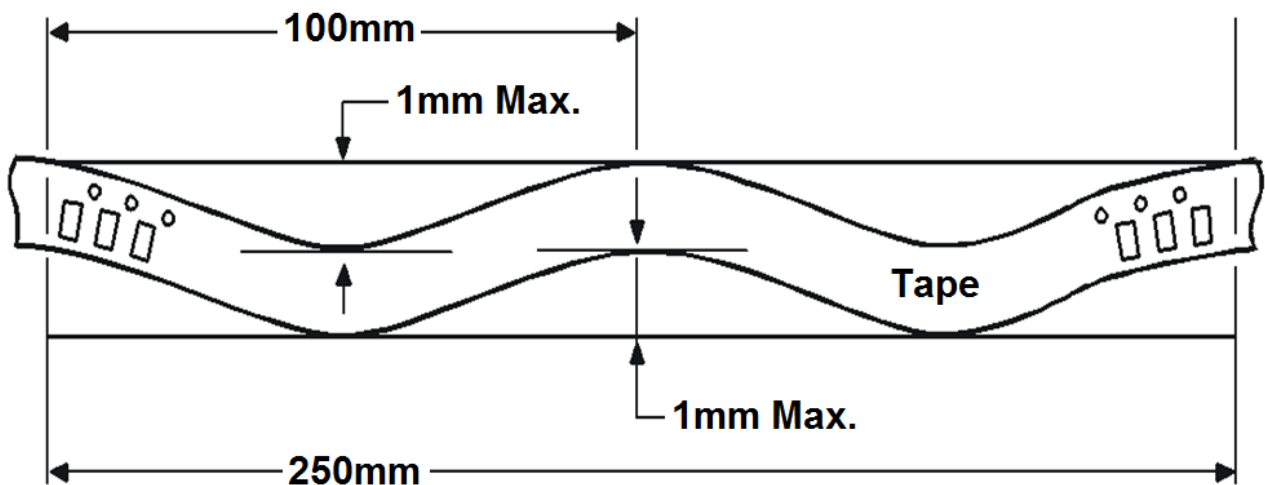
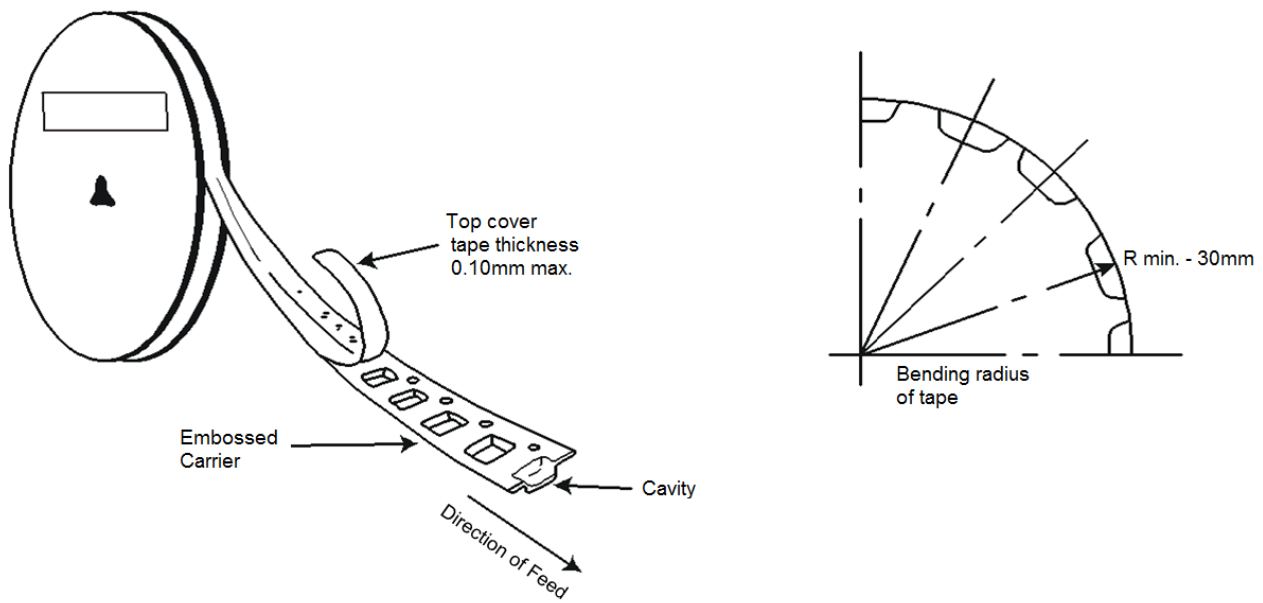

Camber (Top View)

Allowable camber to be 1mm/100mm tape, non-cumulative

Maximum Component Movement in Tape Pocket

**Component Lateral Movement
12mm Tape**

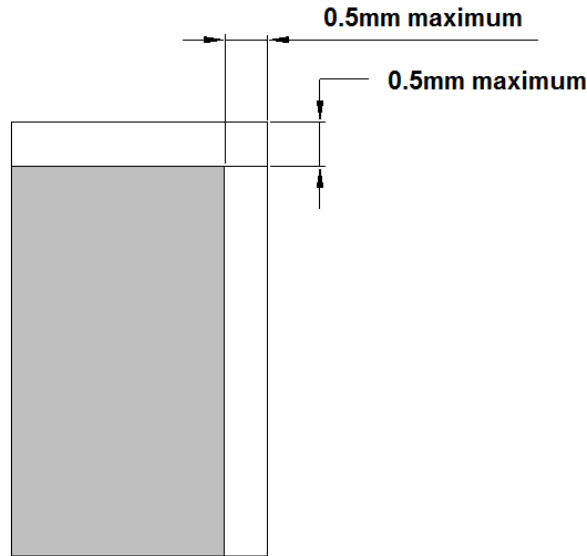

**Maximum Component Rotation
Top View**

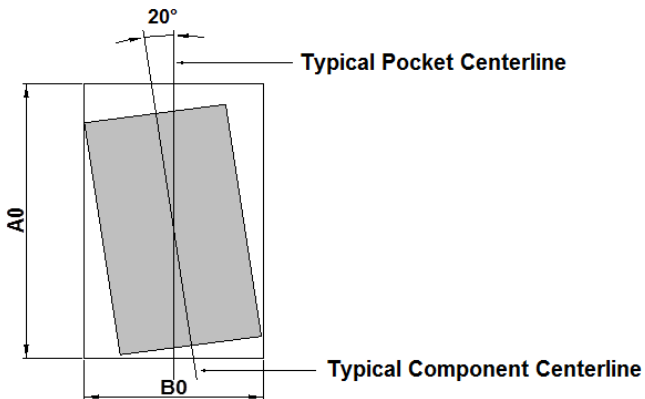

**Maximum Component Rotation
Side View**

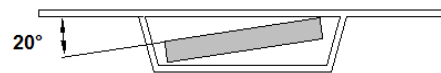

Surface Mount Reel Specifications

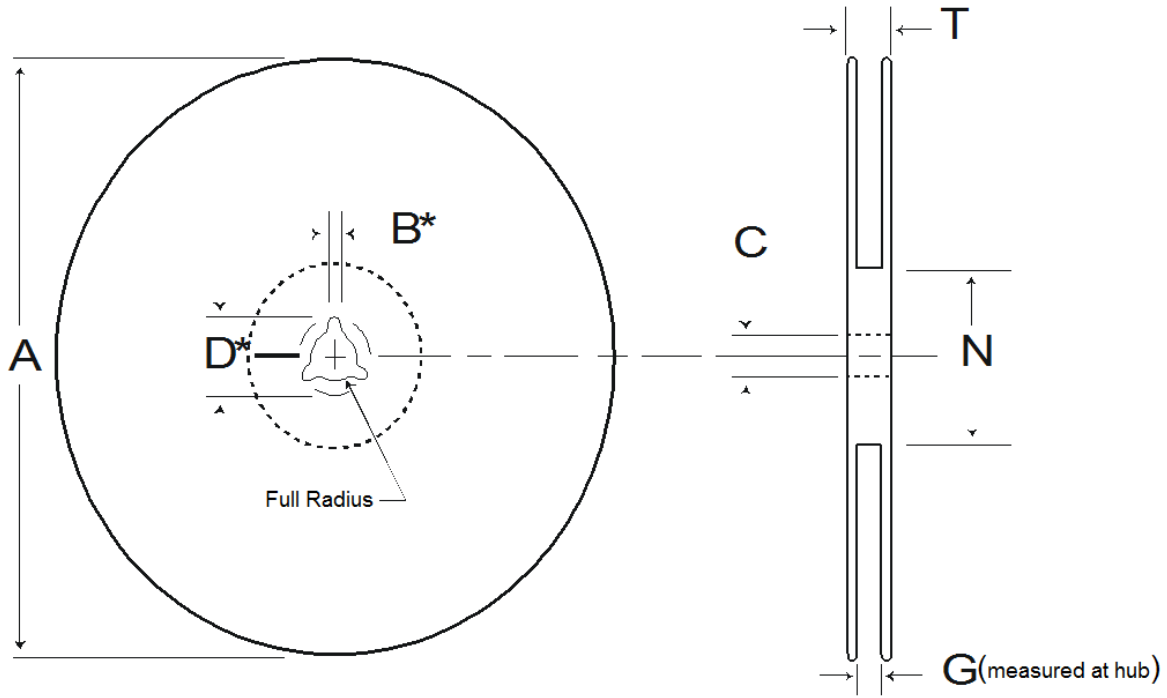

* Drive spokes optional. If used, dimensions with asterisks apply

Tape Width	Reel Size	A (mm)	B Max (mm)	C (mm)	D Max (mm)	N Min (mm)	G (mm)	T Max (mm)
12mm	7"	178 ±2	2.0 +0.5 -0	13 +0.5 -0.2	20.5 ±0.2	55 ±5	12.4 +2.0 -0.0	18.4
	13"	330 ±2	2.0 +0.5 -0	13 +0.5 -0.2	20.5 ±0.2	100 ±2	12.4 +2.0 -0.0	18.4

Tape Leader and Trailer Specifications

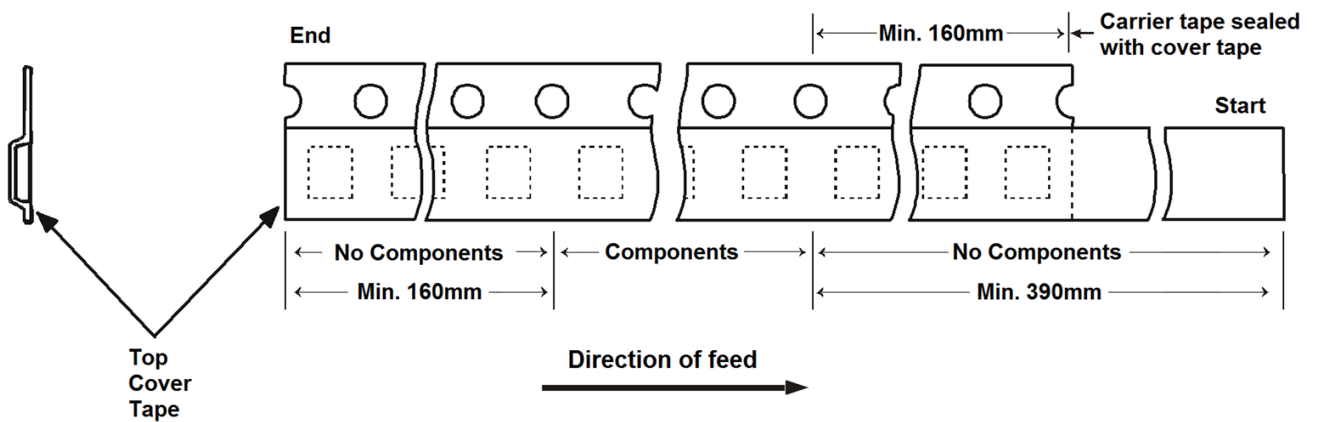

Note: There shall be a leader of at least 230mm which may consist of carrier tape and/or cover tape or a start tape followed by at least 160mm of empty carrier tape sealed with cover tape.

Note: There shall be a trailer of at least 160mm of empty carrier tape sealed with cover tape. The entire carrier tape must release from the reel hub as the last portion of the tape unwinds from the reel without damage to the carrier tape and the remaining components in the cavities.