

- SOT-23-6 (SC-74)

Unit: mm

PACKAGE DIMENSIONS

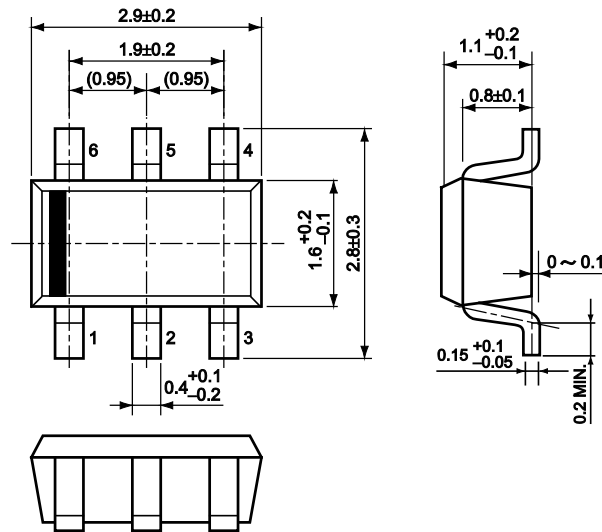

TAPING SPECIFICATION

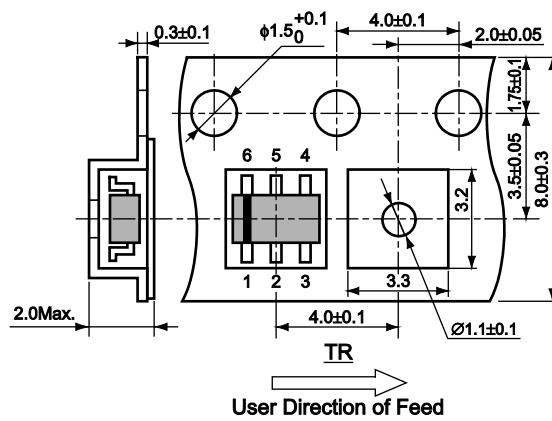

TAPING REEL DIMENSIONS REUSE REEL (EIAJ-RRM-08Bc)

(1reel=3,000pcs)

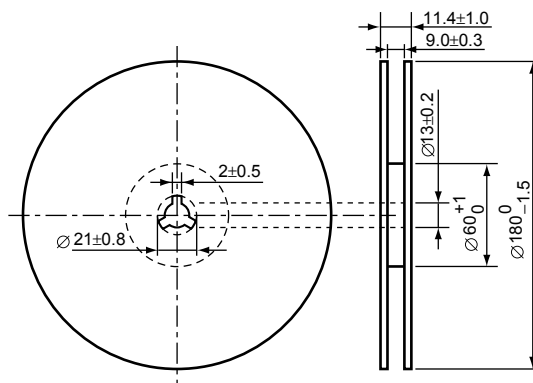

POWER DISSIPATION (SOT-23-6)

This specification is at mounted on board. Power Dissipation (P_D) depends on conditions of mounting on board. This specification is based on the measurement at the condition below:

Measurement Conditions

	Standard Land Pattern
Environment	Mounting on Board (Wind velocity=0m/s)
Board Material	Glass cloth epoxy plastic (Double-sided Board)
Board Dimensions	40 mm × 40 mm × 1.6 mm
Copper Ratio	Top side : Approx. 50% , Back side : Approx. 50%
Through-holes	$\phi 0.5$ mm × 44 pcs

Measurement Results ($T_a=25^\circ\text{C}$)

	Standard Land Pattern	Free Air
Power Dissipation	420 mW ($T_{jmax} = 125^\circ\text{C}$) 525 mW ($T_{jmax} = 150^\circ\text{C}$)	250 mW ($T_{jmax} = 125^\circ\text{C}$) 310 mW ($T_{jmax} = 150^\circ\text{C}$)
Thermal Resistance	$\theta_{ja} = 238^\circ\text{C/W}$	400°C/W

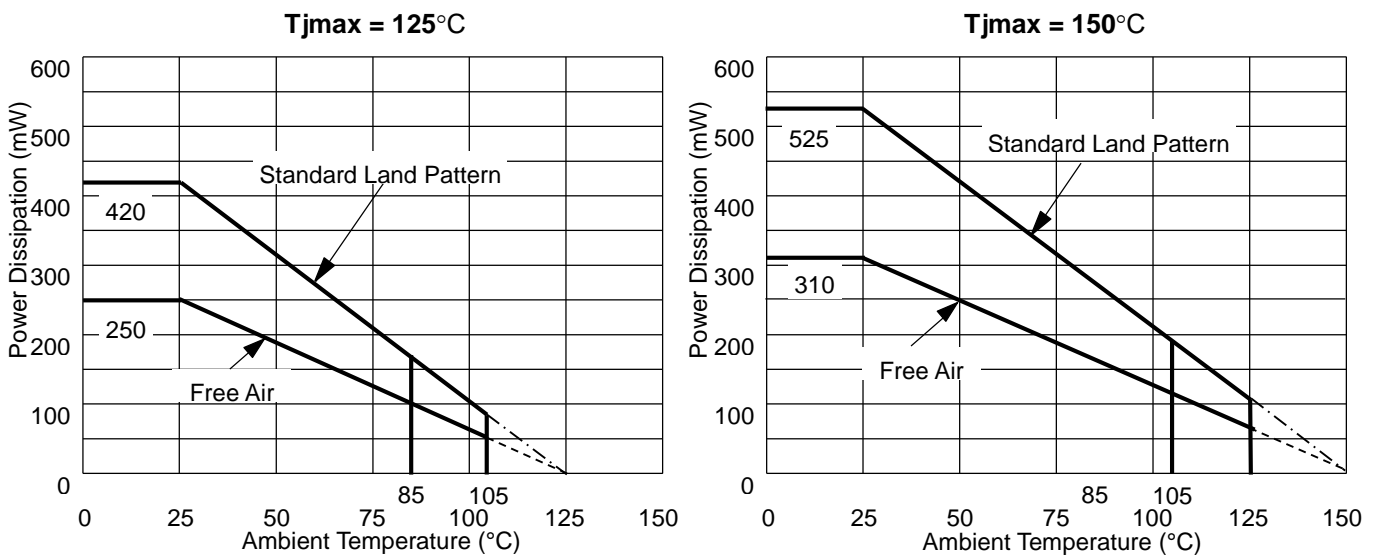

Power Dissipation vs. Ambient Temperature

RECOMMENDED LAND PATTERN

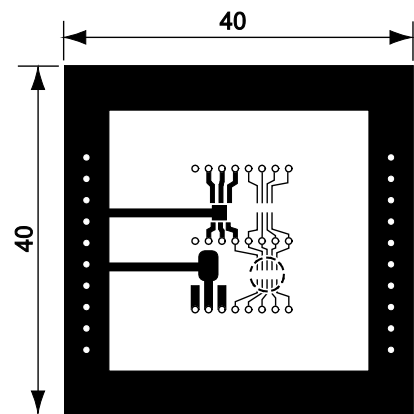
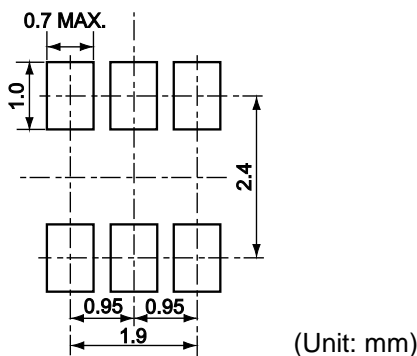

○ IC Mount Area (Unit: mm)
Measurement Board Pattern